



# GATEGUARD

SECURITY BARRIER GATES



MODEL  
**GTG-301**

## Functions & Features

1. Manual release.
2. Machine core with compression spring, effectively avoids the accidents caused by spring breaking.
3. Die-casting aluminium alloy motor, precision and good at thermal radiating.
4. Motor cooling fan, solves the problem of heat-protection.
5. Double safety limit switches (photoelectricity limit switch/motor memory sensor).
6. Reversing on obstacle.
7. Auto-closing.
8. Support the Infrared Photocell for anti-bumpingfunction (optional).
9. Support the external and internal Vehicle Loop Detector (optional).
10. Traffic light interface.
11. Wire control (switch signal), remote control (418 MHz).

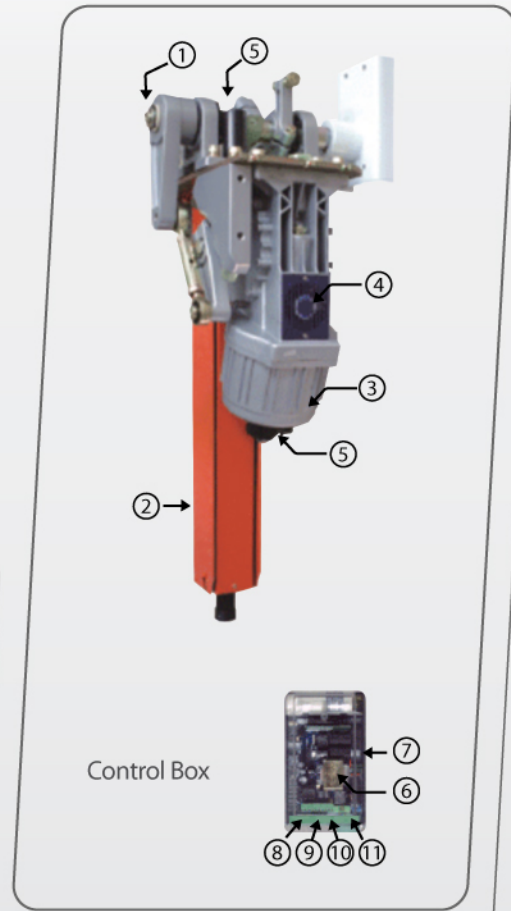
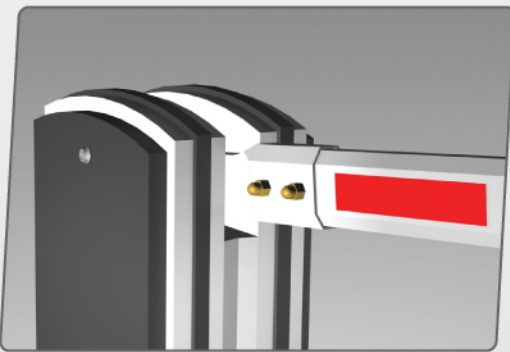

## Technical Data

ITEM	MODEL GTG-301		
Running time	3 sec		
Boom type	Straight		
Boom length	3 m	4.5 m	6 m
Main Boom dimension (WxH)	45 x 100 mm		
Boom weight	4.5kg		
Voltage	220 V ± 10%, 110 V ± 10%		
Frecuency	50 / 60 Hz		
Motor voltage	220 V		
Power	120 W		
Working temperature	-20 °C ~ 75 °C		